

NEOSTONE 2.5

FREESTANDING STOVE
FOR MEDIUM TO LARGE SPACES

Heat Output Cord Wood
85,000 BTU

33,000 BTU EPA Test Fuel

EFFICIENCY (LHV)	80.3%
EMISSIONS	2.85 G/HR
LOG SIZE (MAX)	18 INCHES
FIREBOX SIZE	2.5 CU.FT.
GLASS SIZE	184 SQ.IN.
WEIGHT	TBD

Powerful performance and natural beauty, introducing the Neostone 2.5 for medium to large spaces. Like its smaller cousin the Neostone 1.6, we took our highly efficient Neo 2.5 engine and elegantly wrapped it in soapstone. The natural properties of each unique large-scale piece of mined soapstone retains heat while the stove is in use and slowly releases the heat back into the room, even after the stove is out.

Inside, our solid steel construction, floating firebox and stainless steel baffle make this a truly effective heater. Clean-burning technology reduces emissions while EBT maximizes burn length and fuel efficiency. Raised taller for convenient operation, the Neostone woodstoves are easy to light, easy to load, and easy to use.

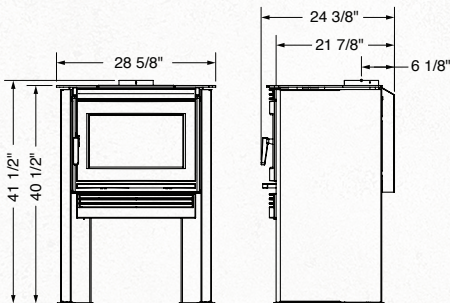

For reference only. Installations should be based on installation manuals. Specifications subject to change.

STANDARD FEATURES

- Reliable, durable non-catalytic technology
- 35mm thick mined Soapstone top and side panels
- Air wash system for super clean ceramic glass
- Easy to use ash disposal system
- High-tech multi-port combustion air injection system
- Inside and outside combustion air capable
- Floating firebox for extended stove life
- 304 Stainless Steel Baffle, insulation cover, rails and flame shield
- Boost air for easy lighting
- Extended Burn Technology (EBT2)
- Integrated heat exchanger
- East-West loading
- Leveling Legs
- Mobile Home Approved

PERFORMANCE OPTIONS

- 140 cfm temperature actuated variable speed blower

SOAPSTONE

Mined soapstone characteristics will vary from stove to stove. Being formed in nature, the appearance of the grain and colour cannot be controlled, making each stove unique.

