

HARMANTM
HOME HEATING

HYDROFLEX60 PELLET BOILER



SPECIFICATIONS

	BTU Range	Heating Capacity*	Hopper Capacity	Fuel Type	Efficiency	Flue Size	Outside Air Size	Water Capacity	Ship Weight	Burn Rate	Floor Protection
HYDROFLEX60	0 - 60,000	2000+ sq. ft.	160 lbs.	Bio-Mass Pellets	90%+	3"	2-3/8"	13 gal. (US)	525 lbs.	0 to 7 lb per hour	46-7/8" x 29-1/8"

CLEARANCES AND DIMENSIONS

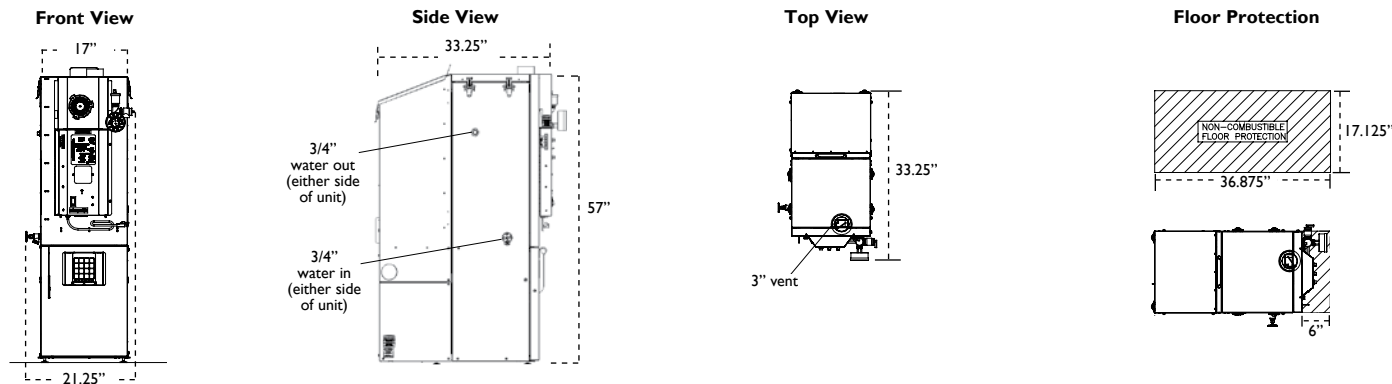

HydroFlex60

GREEN heating at it's best, the HydroFlex60 provides up to 60,000 BTUs to your primary central heating system. Whether you currently have a hot air or a hot water system, the HydroFlex60 will save on heating costs. With it's proven pellet burning system, triple pass heat exchanger and wireless thermostat, the HydroFlex60 will provide a warm, comfortable feeling in your home and wallet.

Growing Market

At Harman, we know you are looking for a cost effective way to heat your home while being considerate to the environment. The Harman HydroFlex60 is the answer, providing a quick and easy way to go green. HydroFlex owners notice remarkably lower energy bills since the HydroFlex uses pellets to heat water and the entire home.

Easy to Install

The HydroFlex has a small footprint which allows installation in tight areas. This unit can connect easily to any existing hot air or hot water system duct work/pipes or remotely connect to the primary unit in another area of the home. The wireless thermostat interfaces with the primary unit and the HydroFlex, keeping your home at your desired temperature.

This feature also gives you the flexibility to use the fuel that is most cost effective at any given time. If the fuel used in your primary system becomes less expensive, you can simply set its thermostat higher and decrease the HydroFlex setting. If pellets remain cost effective, you can keep the HydroFlex temperature at the desired setting and decrease the primary system for back up.

Responsible Heat

Pellet heat is carbon neutral. This means that switching from oil or gas to renewable fuels reduces the home's carbon footprint and makes a positive impact on our atmosphere. The high-efficiency HydroFlex is an excellent source of environmentally responsible heat.

Features

- Small footprint
- Over 90% efficient on high burn
- Patented Pellet Pro feeder and burn pot
- Faster ignition & recovery for quick response to heat needs.
- 14 spiral baffled stainless steel heat exchanger tubes increase efficiency by allowing exhaust gases to travel through the tubes 3 times
- Electronic temperature control
- 120 VAC
- Front door with window for easy ash removal, burnpot access and fire viewing.
- Outside air temperature sensor
- Dual boiler water temperature and pressure gauge
- Pressure relief valve
- Refractory-lined firebox
- Fiberglass insulation surrounding the entire unit
- 3-inch pellet exhaust
- 3/4-inch water lines

Options

- Outside air
- Battery back-up
- Wireless thermostat
- Direct vent wall passthrough
- Bulk hopper (1,400+ lb. hopper capacity)

YOUR HARMAN DEALER IS:

HARMAN
HOME HEATING

352 MOUNTAIN HOUSE ROAD
HALIFAX, PA 17032
WWW.HARMANSTOVES.COM

A BRAND OF HEARTH & HOME TECHNOLOGIES

Actual product appearance, including flame, may differ from image. Tested by OMNI-TEST Laboratories CAN/CSA B366.1-M91 • UL 391 • ASTM E1509-04 • ULC/ORD C1482-M1990 (ULC-S627-00) • Mobile Home-Approved

Harman Warranty The strongest in the industry, Harman provides a warranty on pellet-burning products to be free from defects in materials and workmanship. For full warranty details, visit www.harmanstoves.com
Product specifications and pricing subject to change without notice. The images and descriptions in this brochure are provided to assist you in product selection only.

*Heating capacity is a guideline only and may differ slightly due to climate, building construction and condition, amount and quality of insulation, location of the heater and air movement in the room. Refer to installation manual for complete clearance requirements and specifications.

HAR-1505U-0409